

**PLAN AT MAIN DECK**  
1/4" = 1'-0"

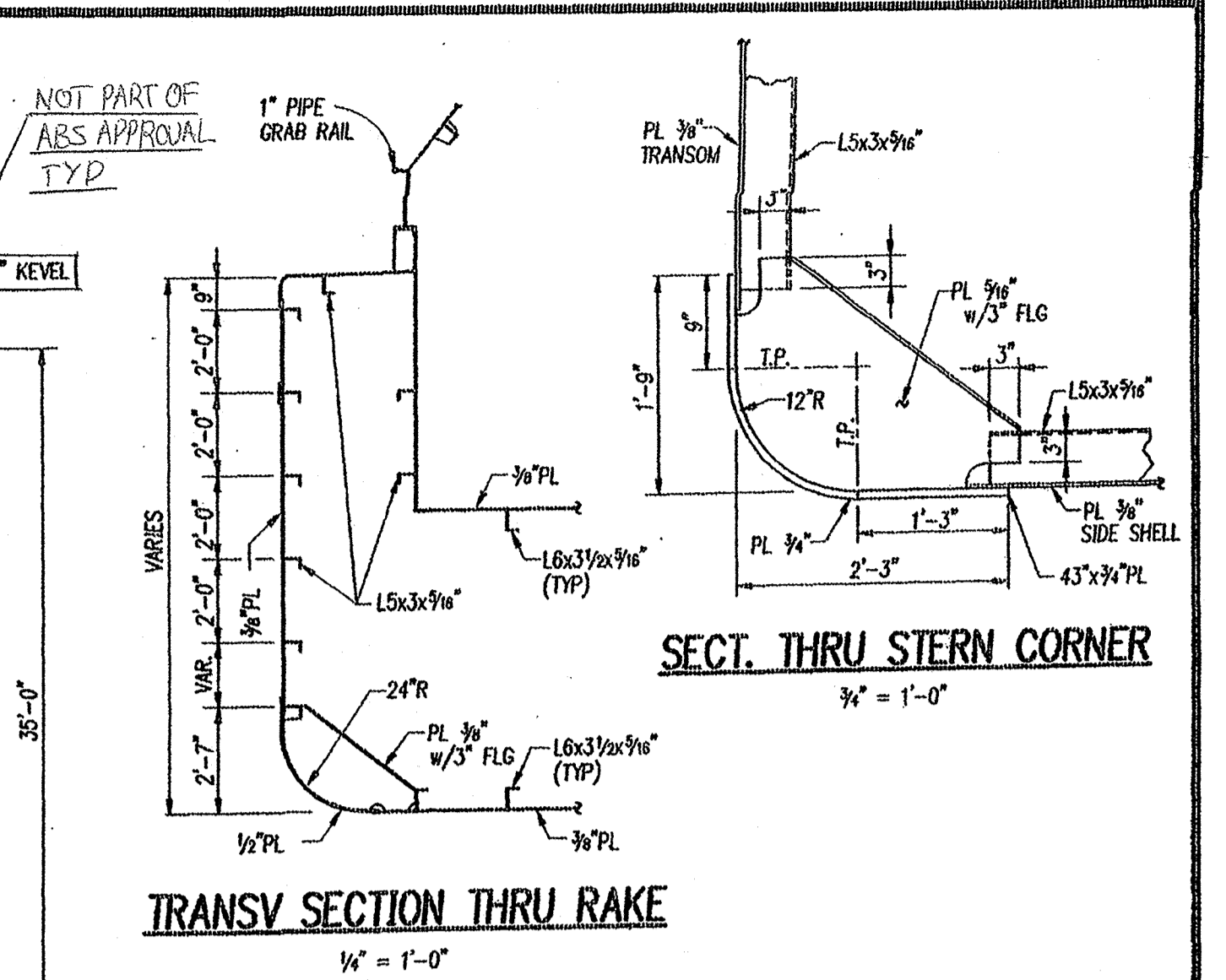

**TRANSV SECTION THRU RAKE**  
1/4" = 1'-0"

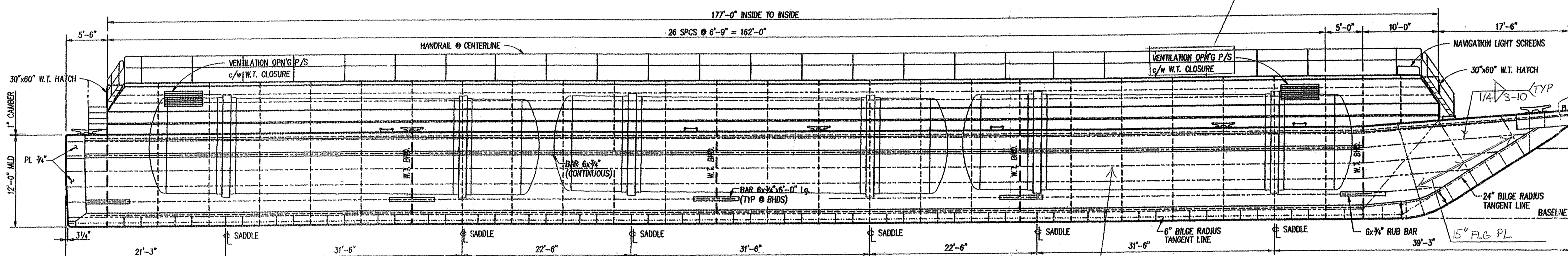

**OUTDR. PROFILE**  
1/4" = 1'-0"

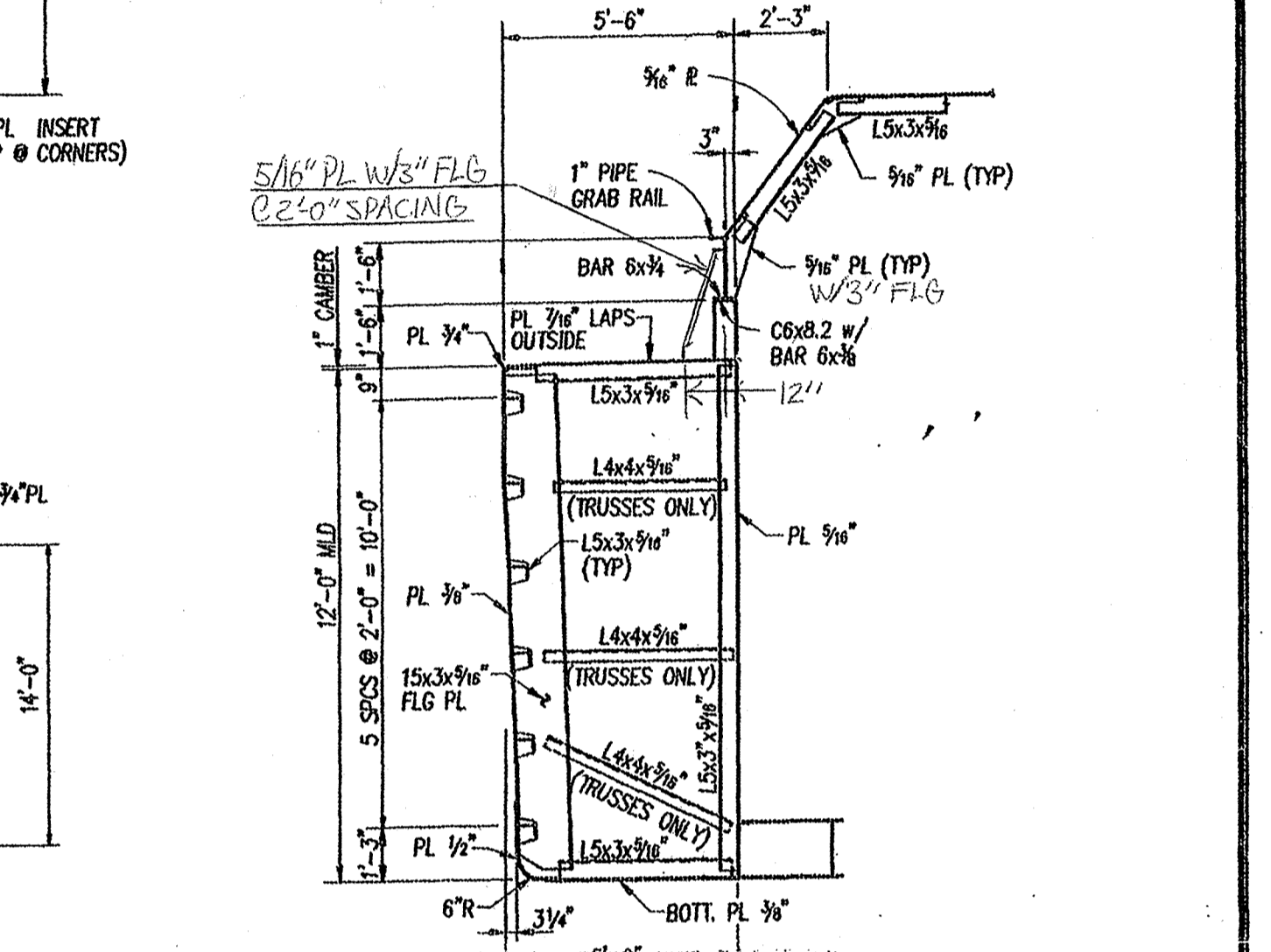

**LONG'L. SECT. THRU STERN**  
1/4" = 1'-0"

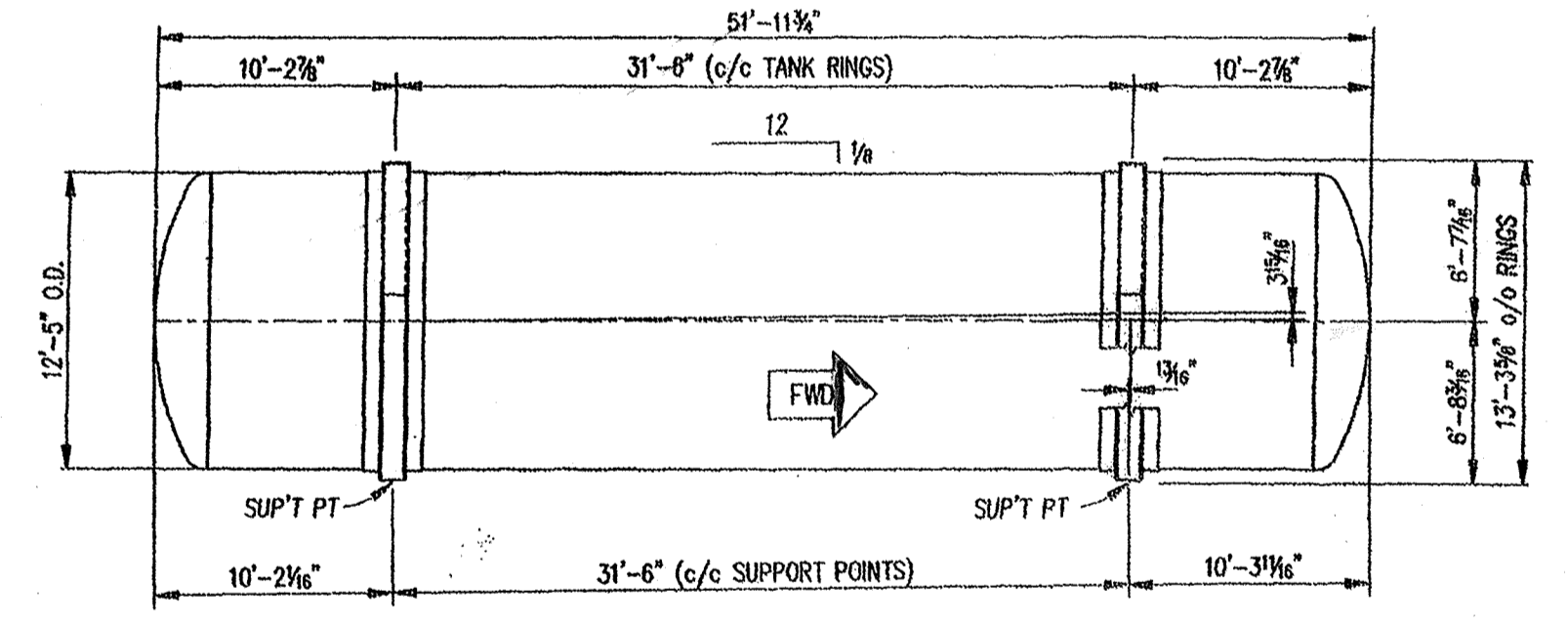

**TANK ELEV. (INSTALLED) SHOWING SUPPORT LOCATIONS**  
1/4" = 1'-0"

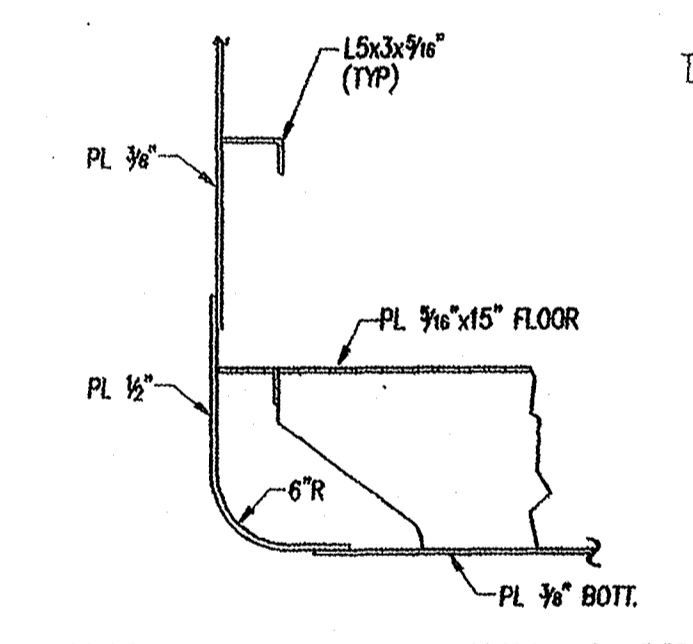

**INTERMED. FLOOR CONN. @ SIDE**  
1/4" = 1'-0"

TO CLASS: A1 INDEPENDENT TANK BARGE

- SUBMIT DETAILS OF WT HATCHES & MANHOLES
- SUBMIT ADDITIONAL DETAILS OF TANK SADDLE SUPPORTS
- PROVIDE COLLISION & ANTI-ROLL CHOCKS
- FIT-UP & WELDING TO SATISFACTION OF ATTENDING SURVEYOR.
- MATERIAL TO SURVEYOR'S SATISFACTION

REVIEWED as indicated in ABS Letter dated: **AS AMENDED** MAY 3 0 2006

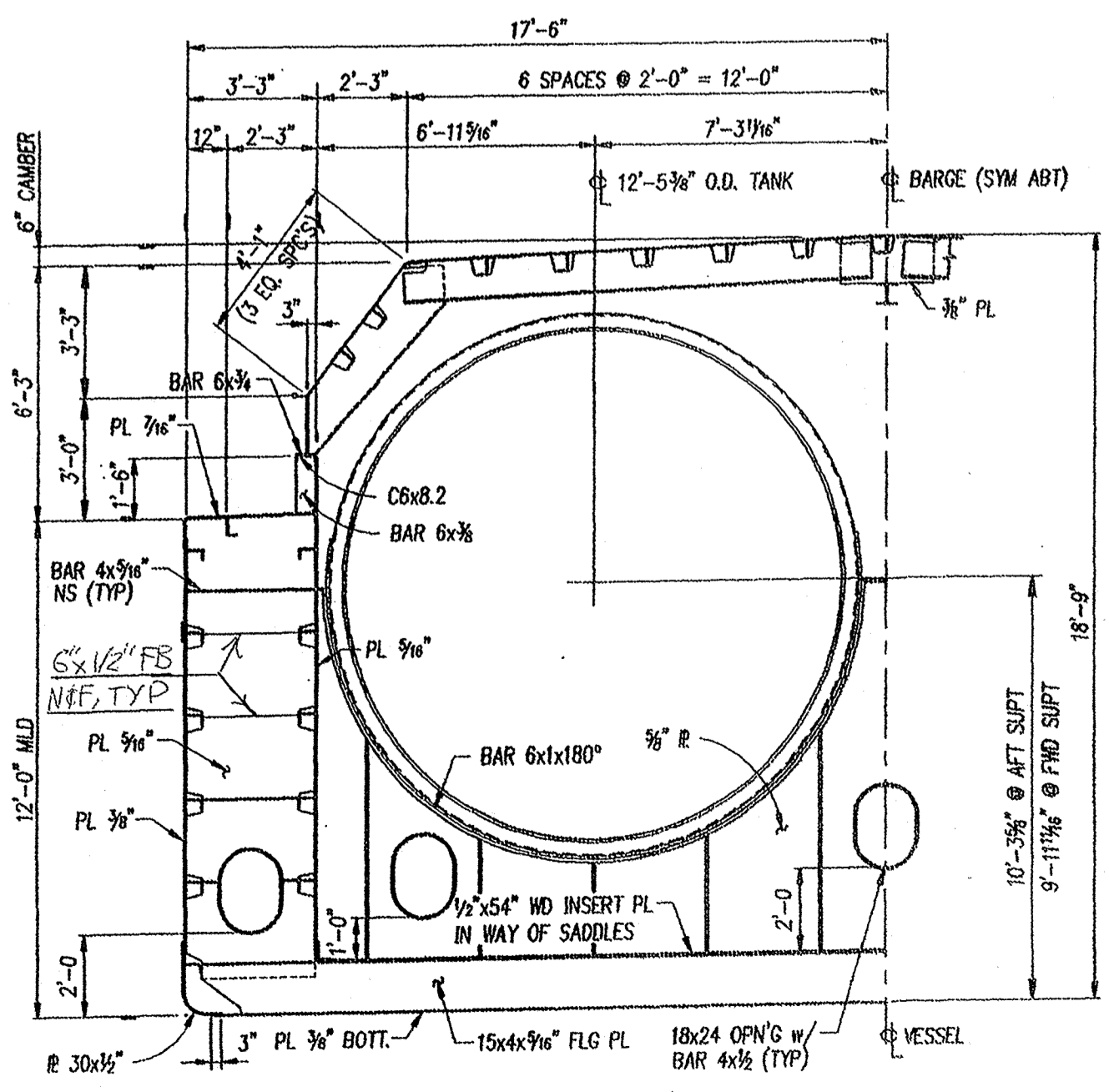

**TRANSV. SECTION THRU AFT TANK SADDLE**  
1/4" = 1'-0"

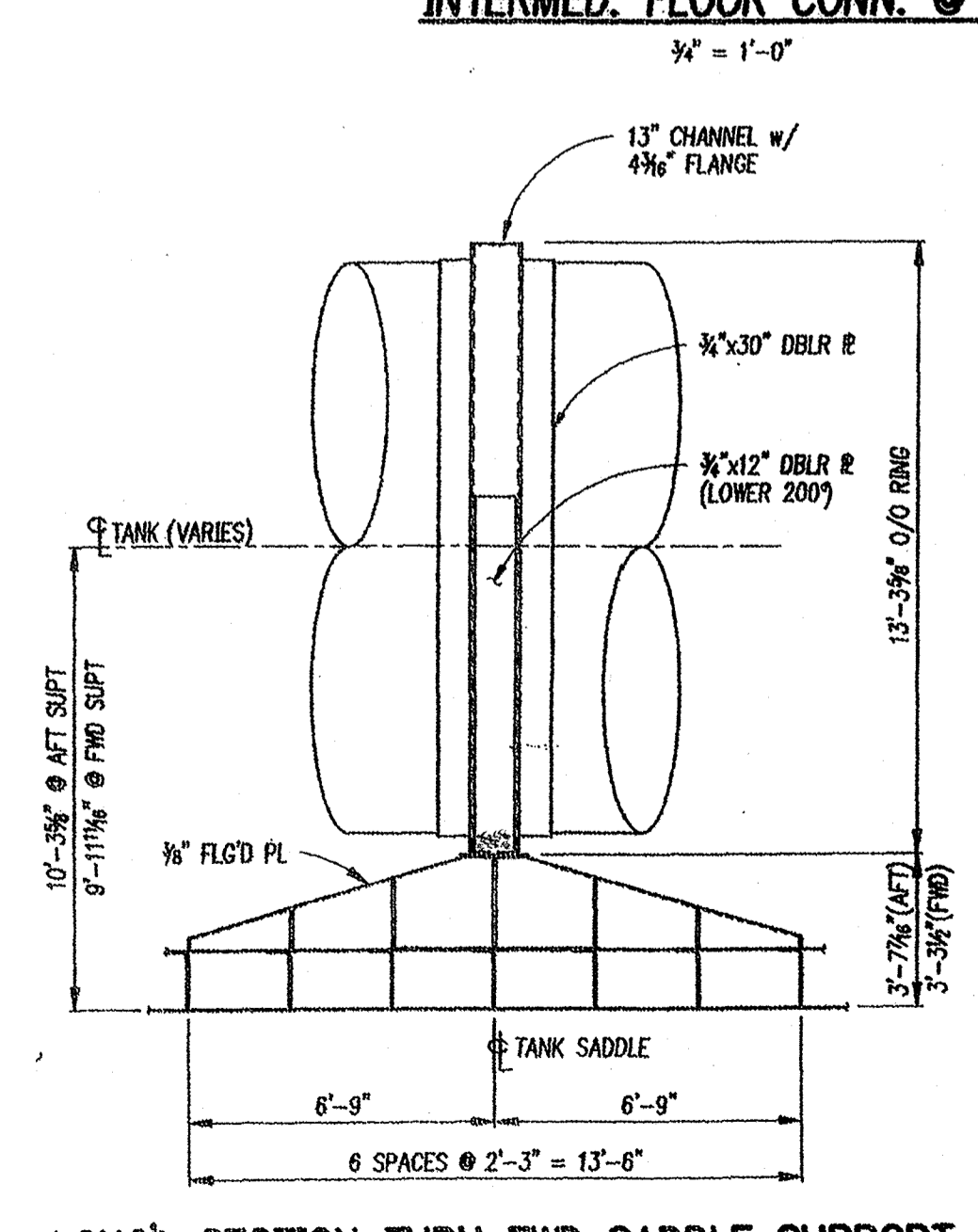

**LONG'L. SECTION THRU FWD SADDLE SUPPORT**  
1/4" = 1'-0"

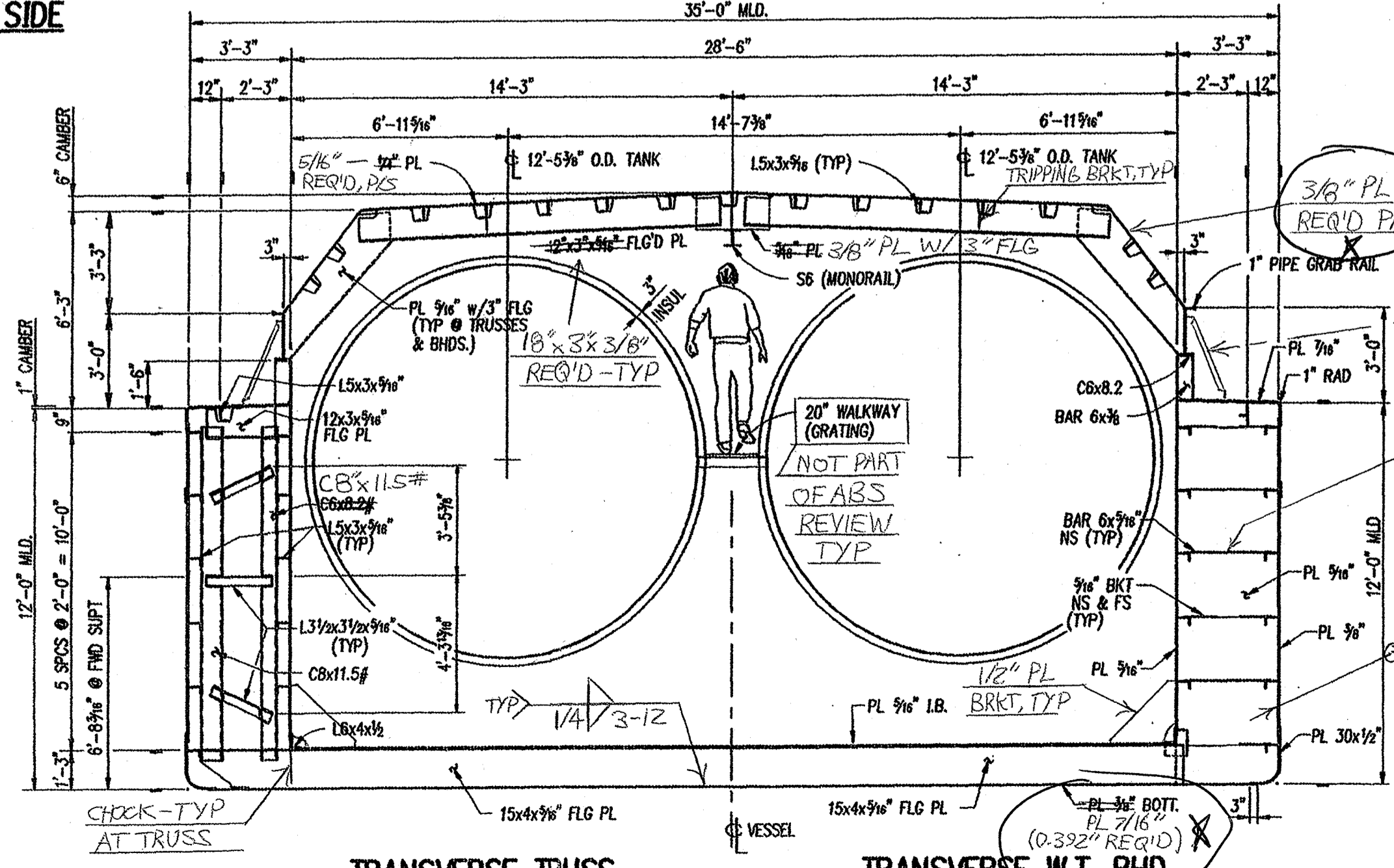

**TRANSVERSE TRUSS**  
1/4" = 1'-0"

**TRANSVERSE W.T. BHD**  
1/4" = 1'-0"

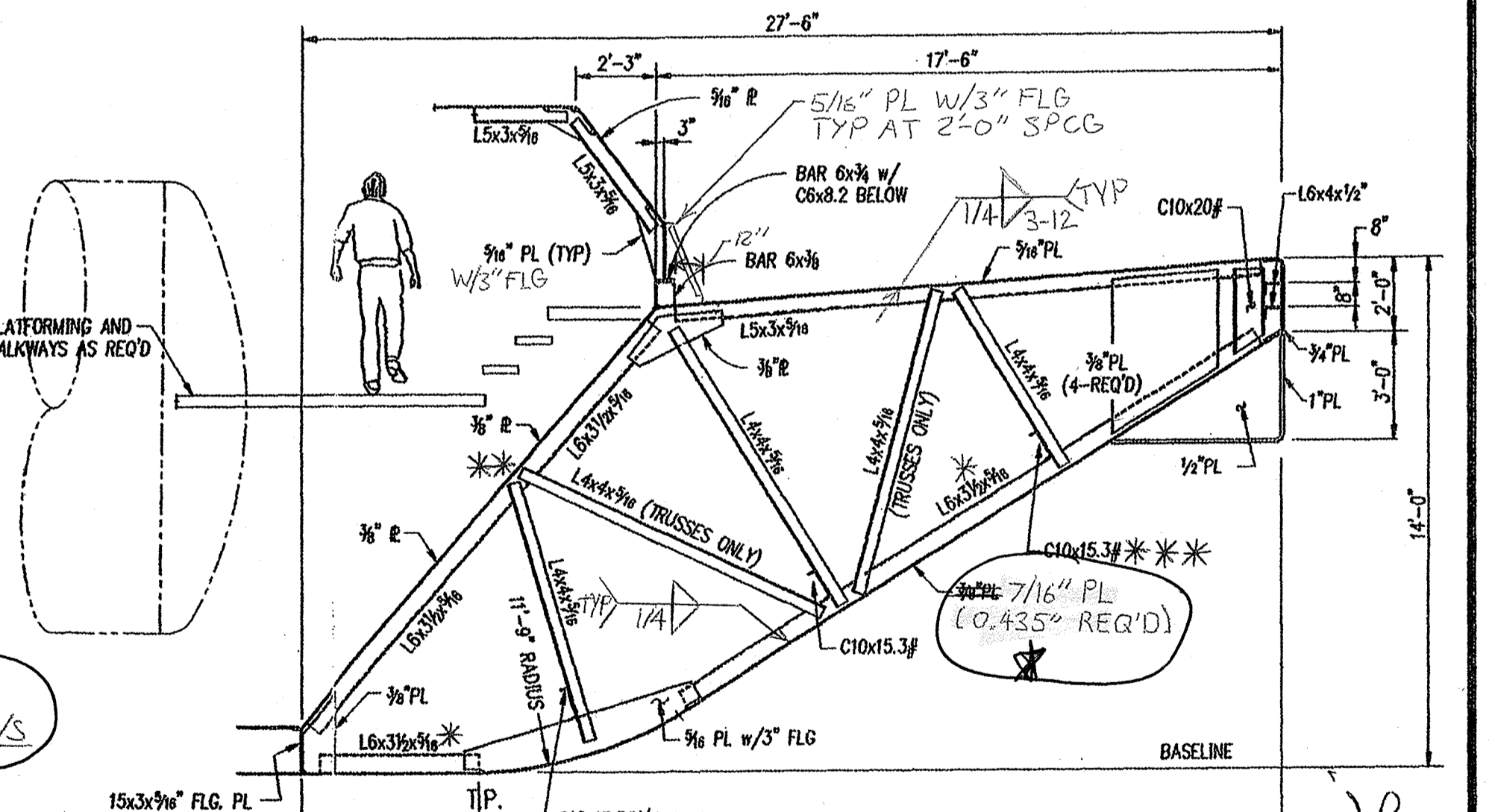

**TYPICAL LONG'L. TRUSS**  
1/4" = 1'-0"

\* 15" FLG PL REQ'D @ MIN 3 LOCATIONS: CL @ 9'-10" OFF CL, P/S

\*\* WELD AREA AT ENDS OF STANCHIONS & DIAGONALS TO BE MIN 75% AREA OF DIAGONALS

\*\*\* 1/2" x 11" FILLER PL REQ'D BTW BOTTOM LONG'L

NO.	REVISION	BY	DATE
2	GENERAL REVISION	CJB	5-15-97
1	REV. TANK SADDLES & LOC'S; REV. INSUL THK; ADDED HANDRAILS & STAIRS; ADDED LIGHT SCREENS; REV. FRAMING & OPENINGS; REV. SECTION THRU RAKE	CJB	5-7-97

**SHEARER & ASSOC., INC.**  
**NAVAL ARCHITECTS**  
NEW ORLEANS • HOUSTON • NASHVILLE

200' 195'-0" x 35'-0" x 12'-0"  
INDEPENDENT TANK BARGE

© 1997, SHEARER & ASSOC., INC.  
THIS DRAWING IN DETAIL AND DESIGN IS PROPRIETARY TO SHEARER & ASSOC., INC., AND MAY NOT BE REPRODUCED AND/OR UTILIZED, IN PART OR WHOLE, WITHOUT THE WRITABLE CONSENT OF SHEARER & ASSOC., INC., AND IS TO BE RETURNED UPON REQUEST.

SCALE: 1/4" = 1'-0" U.M. APPROVED BY: DRAWN BY: CJB  
DATE: 4-23-97 REV. NO. 2

CARGILL FOODS, INC.  
GENERAL ARRANGEMENT DRAWING NUMBER 970203-1